



承认书

产品型号: DW1560B2Z0

产品规格: 1920RGB * 1080 INNO TFT 液晶显示屏

送承方: Kingtech Group Co.,Ltd.

制订	审查	核准	公司印章
 2021.04.22			

承认方:

研发部	工程部	品质部	核准	公司印章

临时规格书

正式规格书



Document Revision History

Version	Date	Page	Description	Changed By
V00	2021-04-22	-	First issue	王加林



Index

Contents	Page
1. LCM Specification	4
2. Mechanical Specification.....	5
3. Pin Descriptions.....	6
4. Electrical Units.....	7
5. AC Characteristics.....	9
6. Power On/Off Sequence.....	13
7. Optical Specifications.....	15
8. Reliability Test Items.....	19
9. Handling Precautions.....	20
10. QC.....	21



1. LCM Specification

1.1 Description

DW1560B2Z0 is a transmissive type color active matrix liquid crystal display(LCD) which uses amorphous thin film transistor(TFT) as switching devices. This product is composed of a TFT LCD panel, 4 drives IC, a PCBA and a LED-backlight unit. The active display area is 15.6 inches diagonally measured and the native resolution is 1920*RGB*1080. Features of this product are listed in the following table.

1.2 Functions & Features

Table 1.1 Module Functions & Features

Parameter	Value	Unit
LCD Mode	TFT/Transmissive	-
Color Depth	16.7M	-
Display Resolution	1920RGB*1080	pixels
Module Size	204.9(H)*350.7(W)*2.90(T)(Exclude PCBA)	mm
Active Area (A.A)	193.59(H)*344.16(W)	mm
Pixel Arrangement	RGB-stripe	-
Viewing Direction	ALL	
Display Mode	Normally Black	
LCD Controller/Driver	ILI6145A	-
IC Package Type	COG	-
Interface	eDP	-
Power Supply Voltage	3.0~3.6	V
Back-light	White LED*40	PCS



2. Mechanical Specification

PIN NO.	SYMBOL
1	CABC_ENABLE
2	H_GND
3	eDP_RX1-
4	eDP_RX1+
5	H_GND
6	eDP_RX0-
7	eDP_RX0+
8	H_GND
9	eDP_AUX_CH+
10	eDP_AUX_CH-
11	H_GND
12	VCC_3.3V
13	VCC_3.3V
14	LCD_SerF_Test
15	H_GND
16	H_GND
17	HPD
18	BL_LED-
19	BL_LED-
20	BL_LED-
21	BL_LED-
22	BL_ENABLE
23	BL_PWM
24	NC
25	NC
26	BL_LED+
27	BL_LED+
28	BL_LED+
29	BL_LED+
30	NC

LED 电路图

LCM Brightness	230cd/m2(MIN) 250 cd/m2(TYP)
Display Type	IFT/NormallyBlack/TRANSMISSIVE
Display Resolution	DDTS1920RGB*1080
Viewing Angle	ALL
LCD Controller/Driver	ILI614SA
Logic Voltage	3.3V
Operation Temperature	0°C ~ 70°C
Storage Temperature	-10°C ~ 70°C
Backlight Spec.	White LED (10 dies in series 4 parallel I=80mA V=30V)

Kingtech Group Co., Ltd.	
TITLE:	DW1560B2Z0
DDC. NO.	
PART NO.	
REV. 1.0	SHEET 1 OF 1
SCALE 1:1	UNITS: mm

DRAWN:	蒋雨吉
CHECK:	
DATE	20210421
DESCRIPTION	新制订
APPROVE:	王加林

REV. 1.0	DATE 20210421
DESCRIPTION	新制订
APPROVE:	王加林

RoHS

DW-2015-0090



3. Pin Descriptions

Pin No.	Symbol	I/O	Functional	Remark
1	CABC_EN	I	No Connection.	
2	H_GND	P	System ground.	
3	eDP_RX1-	I/O	eDP RX channel 1 negative	
4	eDP_RX1+	I/O	eDP RX channel 1 positive	
5	H_GND	P	System ground.	
6	eDP_RX0-	I/O	eDP RX channel 0 negative	
7	eDP_RX0+	I/O	eDP RX channel 0 positive	
8	H_GND	P	System ground.	
9	eDP_AUX_CH+	I/O	eDP AUX CH positive	
10	eDP_AUX_CH-	I/O	eDP AUX CH negative	
11	H_GND	P	System ground.	
12-13	VCC_3.3V	P	Power Supply, 3.3V (typ.)	
14	LCD_Self	I	No Connection.	
15-16	H_GND	P	System ground.	
17	HPD	O	Hot plug detect output.	
18-21	BL_LED-	I	LED Power supply -, If not use, N.C	
22	BL_EN	I	LED enable pin Input(3.3V), If not use ,N.C	
23	BL_PWM	I	System PWM Signal Input; If not use, N.C	
24-25	N.C		No Connection.	
26-29	BL_LED+		LED Power supply +,5V-21V, If not use, N.C	
30	N.C		No Connection.	

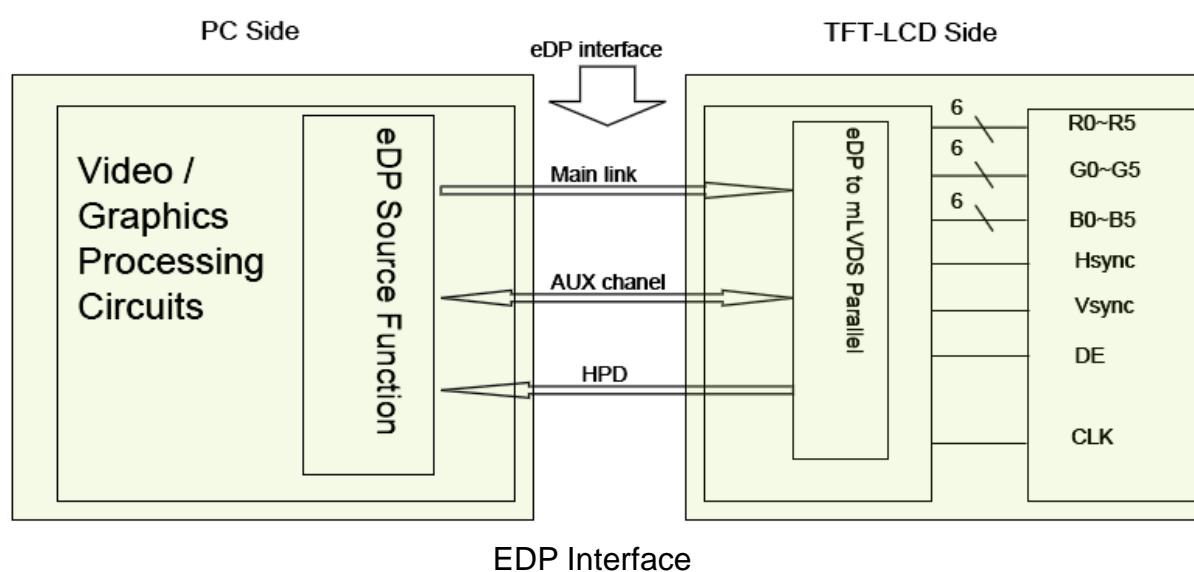



4. Electrical Units

4.1 Absolute Maximum Ratings

The absolute maximum ratings are list on Table 4.1. When used out of the absolute maximum ratings, the LCM may be permanently damaged. Using the LCM within the following electrical characteristics limit is strongly recommended for normal operation. If these electrical characteristic conditions are exceeded during normal operation, the LCM will malfunction and cause poor reliability.

Table 4.1 Module Absolute Maximum Ratings

Item	Symbol	Unit	Value	Note
Power Supply Voltage (1)	Vdd	V	-0.3 to +4.0	
Power Supply Voltage (2)	VGH ~ VSS	V	-0.3 to +25	
Power Supply Voltage (3)	VSS ~ VGL	V	0 to -10.0	
Operating Temperature	Top	°C	0 to +70	
Storage Temperature	Tst	°C	-10 to +70	
Operating Humidity	Hop	%(RH)	10~85	

(VSS=0V)

4.2 Electrical characteristics (Ta=25°C)

Table 4.2:DC Characteristic (Vcc = 3.0 ~ 3.6V)

Item		Symbol	Condition	Min.	Type.	Max.	Unit
Supply Voltage	Logic	Vdd	---	3.0	3.3	3.6	V
Input Voltage	H level	V _{IH}	---	0.7V _{dd}	---	V _{dd}	V
	L level	V _{IL}		0	---	0.3V _{dd}	
Current Consumption		I _{DD}	With internal voltage generation; VDD=3.3V; Tamb=25°C;	---	310	---	mA



4.3 Back-light Specification

Table 4.3 Back-light Characteristics

Item	Symbol	Conditions	Min.	Type.	Max.	Unit
Supply Voltage	VF	Only Backlight	28	30	32	V
Supply Current	IF		80			mA
Average Brightness	IV	Backlight Current IF=80mA	3800	4200	-	Cd/ m ²
CIE Color Coordinate (Without LCD)	X	Backlight Current IF=80mA	0.309	--	0.313	-
	Y		0.334	--	0.360	
Uniformity	B	Backlight Current IF=80mA	--	75%	-	%
Color	White					

Note: 10 LEDs in series 4 parallel connection.



5. AC Characteristics

5.1 eDP Interface Timing

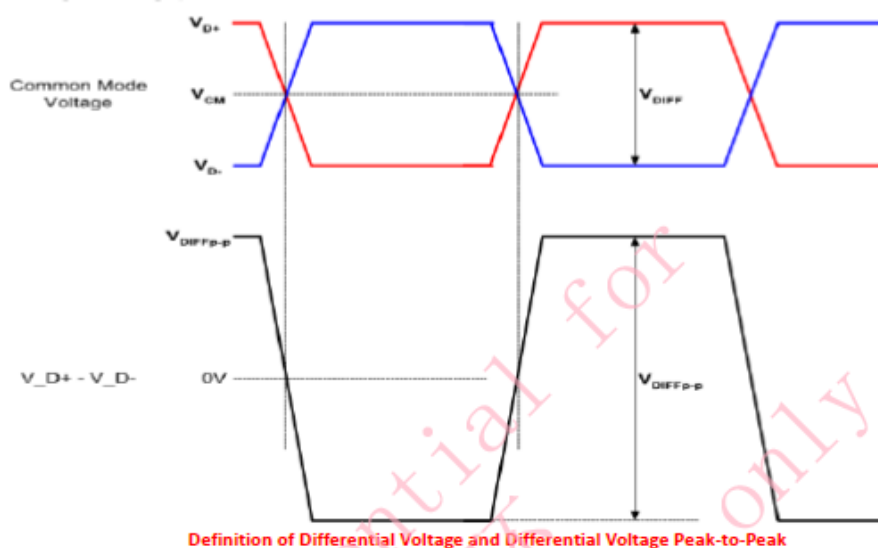

DC Specification	Min	Typ	Max	Unit
DC common mode voltage	0		2	V
AC Specification	Min	Typ	Max	Unit
Frequency for high bit rate	2.68569	2.7	2.70081	Gbps
Frequency for reduced bit rate	1.611414	1.62	1.620486	Gbps
Spread spectrum clock (down spreading)	0		0.5	%
SSC modulation frequency	30		33	kHz
Differential peak-to-peak input voltage at package pins	100	-	1320	mV
Rx input DC common mode voltage	0	-	2	V
Differential termination resistance	80	-	120	ohm
Single-ended termination resistance	40	-	60	ohm
Rx short circuit current limit	-	-	50	mA
RX intra-pair skew tolerance at HBR	-	-	60	ps
Clock frequency	-	-	160	MHz

5.2 HDP characteristics

VDDRX, VDDTX, VDDC=1.2V, VDDIO25=2.5V, VDDIO18=1.8V, Ta = 25°C						
Symbol	Symbol Parameter	Limits			Unit	Conditions
		Min	Typ	Max		
VOH_HPD	HPD voltage	2.25		2.75	V	IOH=0mA
THPD_IRQ	HPD_IRQ pulse width	0.5		1	Ms	

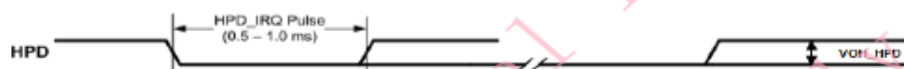



6. Power On/Off Sequence

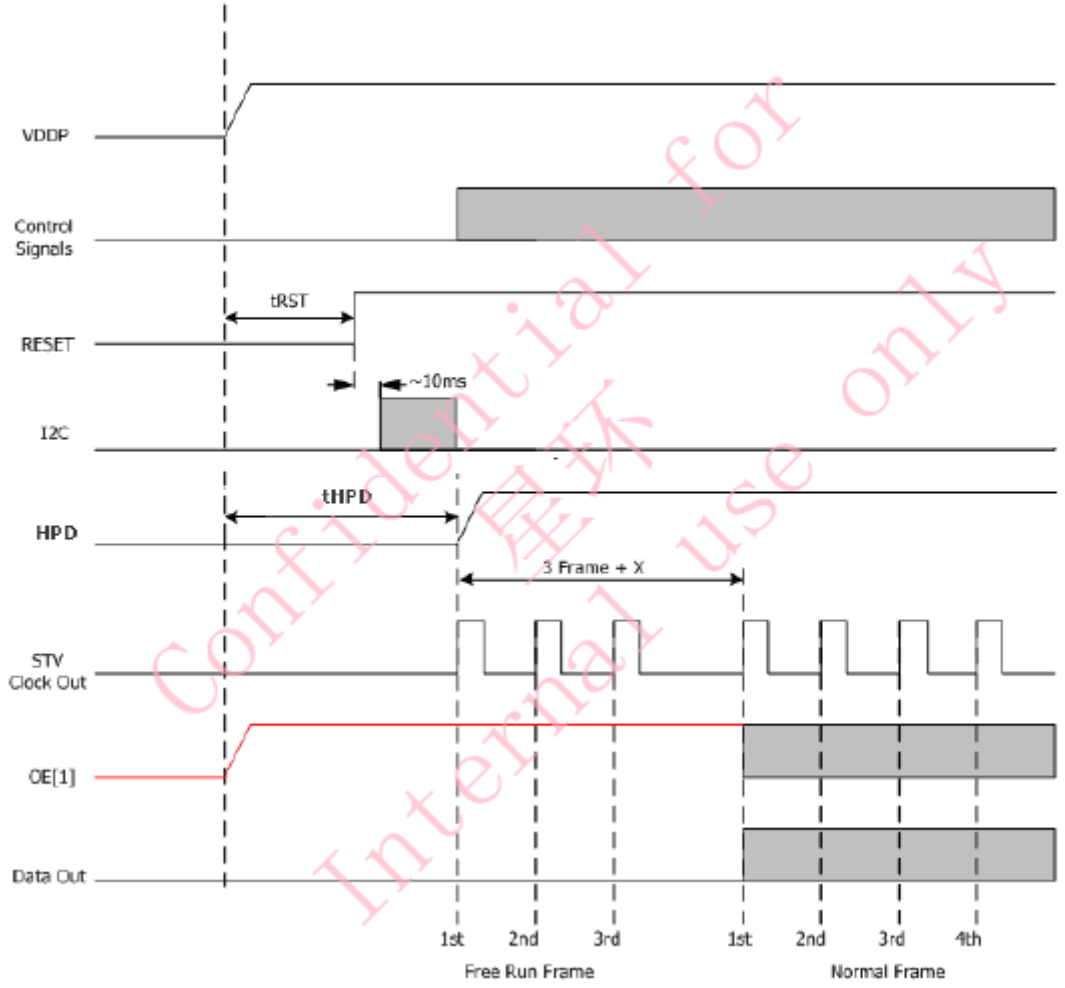



7. Optical Specifications

Optical characteristics are determined after the unit has been 'ON' and stable for approximately 30 minutes in a dark environment at 25°C. The values specified are at an approximate distance 50cm from the TFT-LCD surface at a viewing angle of Φ and θ equal to 0° .

Measurement condition: Refer to next pages (C-light source, Halogen Lamp)

*1): with Polarizer *2): without Polarizer *3): Only Color Filter glass

Item	Symbol	Conditions	Specifications			Unit
			Min.	Typ.	Max.	
Transmittance (w/o APCF, w/o Haze) (w/o WPA)	T%	Viewing normal angle $\theta_x = \theta_y = 0^\circ$	--	6.38	--	%
Contrast Ratio (w/o WPA)	CR		800	1000	--	--
Response Time (w/o WPA)	$T_{on} + T_{off}$		--	--	30	ms
Viewing Angle	Hor.	θ_{x+}	--	80	--	deg.
		θ_{x-}	--	80	--	
	Ver.	θ_{y+}	--	80	--	
		θ_{y-}	--	80	--	
CF only Color Chromaticity (CIE 1931)	Red	Rx	0.577	0.597	0.617	-
		Ry	0.314	0.334	0.354	-
	Green	Gx	0.274	0.294	0.314	-
		Gy	0.498	0.518	0.538	-
	Blue	Bx	0.122	0.142	0.162	-
		By	0.131	0.151	0.171	-
	White	Wx	0.286	0.306	0.326	-
		Wy	0.308	0.328	0.348	-
	NTSC% (x, y)			34	44	



Notes : 1. Contrast Ratio(CR) is defined mathematically as :

$$\text{Contrast Ratio} = \frac{\text{Surface Luminance with all white pixels}}{\text{Surface Luminance with all black pixels}}$$

2. Surface luminance is the center point across the TFT-LCD surface 500mm from the surface with all pixels displaying white. For more information see FIG 1.
3. Response time is the time required for the display to transition from white to black(Rise Time, Tr) and from black to white(Falling Time, Tf). For additional information see FIG 3.
4. Viewing angle is the angle at which the contrast ratio is greater than 10. The angles are determined for the horizontal or x axis and the vertical or y axis with respect to the z axis which is normal to the TFT-LCD surface. For more information see FIG 4.
5. Optimum contrast is obtained by adjusting the TFT-LCD Threshold voltage(Vth & Vsat)

FIG. 1 Optical Characteristic Measurement Equipment and Method

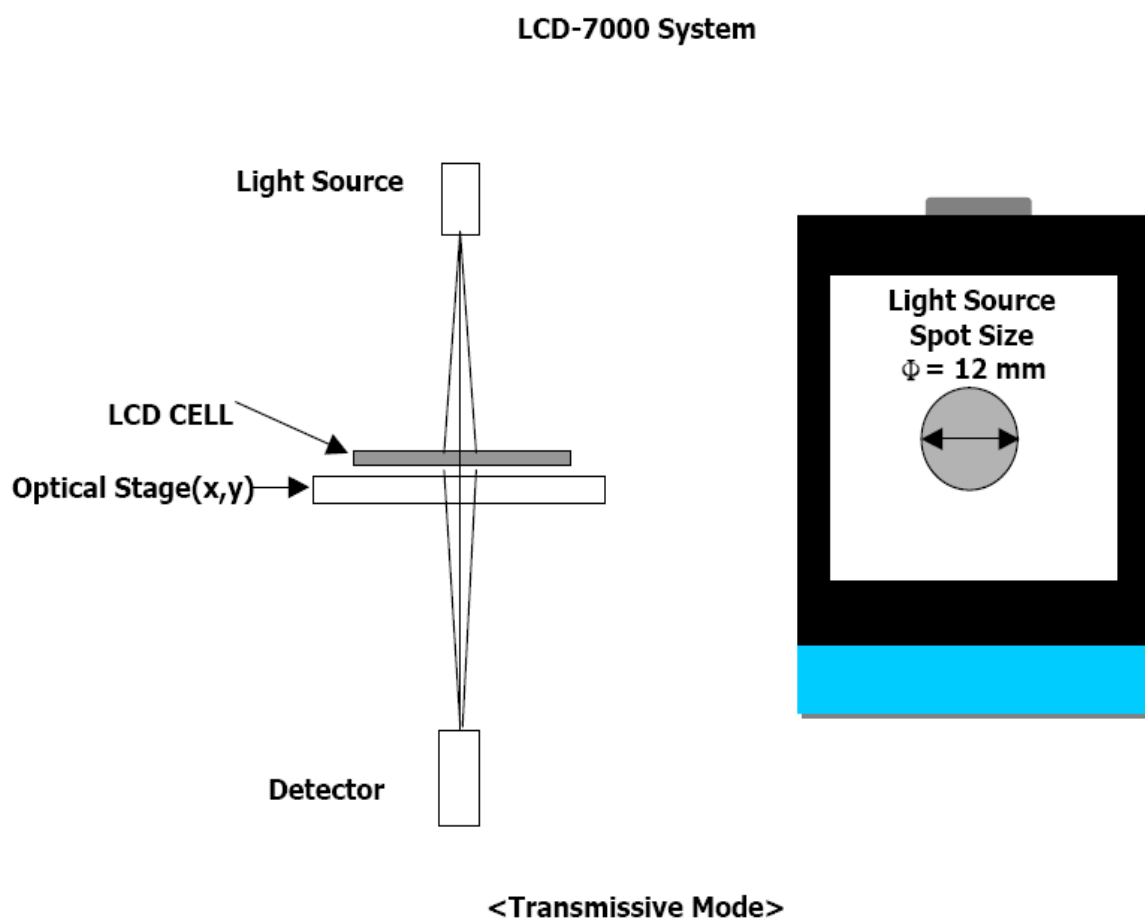



FIG. 2 The definition of V_{th} and V_{sat}

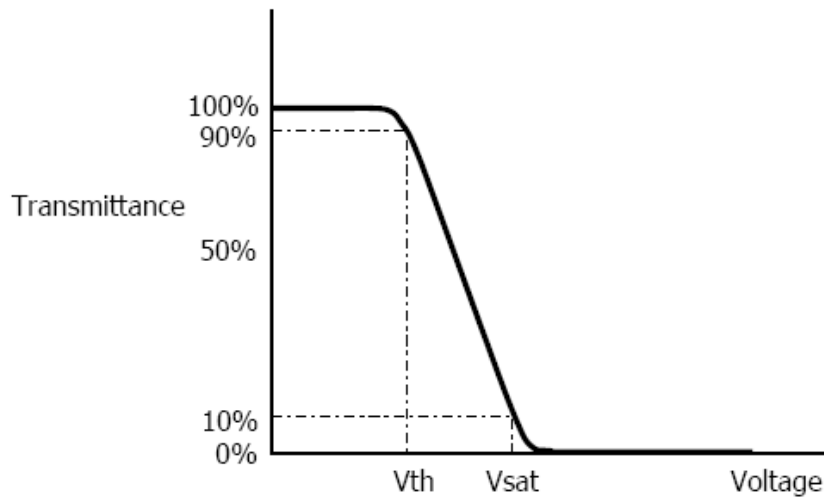
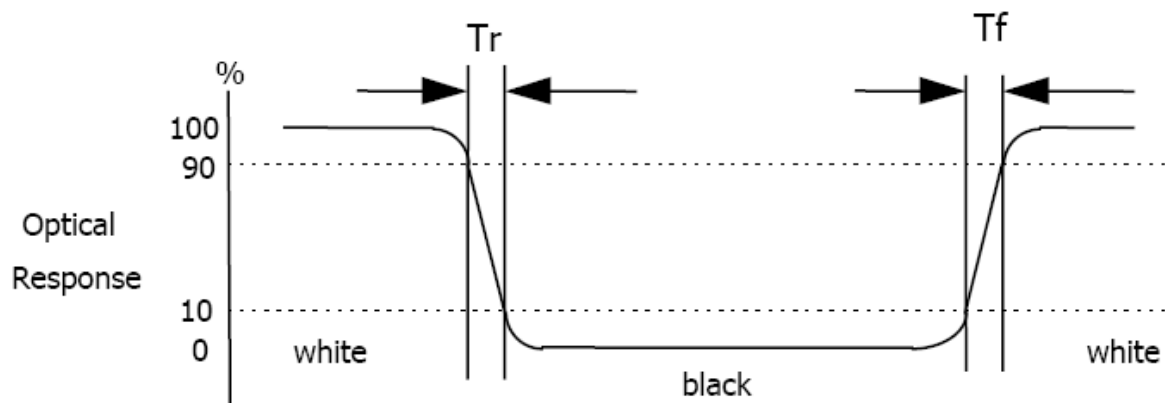

FIG. 3 The definition of Response Time

The response time is defined as the following figure and shall be measured by switching the input signal for "black" and "white".



* Voltage conditions for Response time

V_{gate} : 19V DC

V_{data} : 0V~3.3V DC

V_{com} : 0V (Ground)



FIG. 4 The definition of viewing angle

<dimension of viewing angle range>

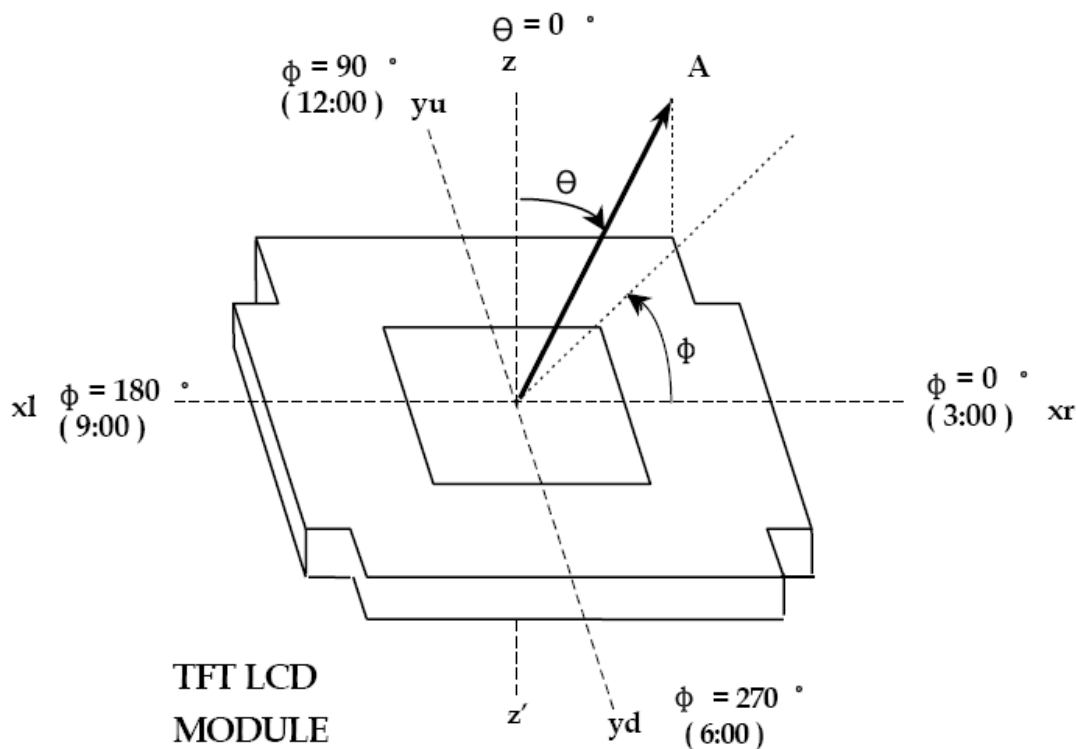

8. Reliability Test Items

No.	Test Item	Test Condition	Check Time
1	High temp storage	T=70°C	96Hrs
2	Low temp storage	T=-10°C	96Hrs
3	High temp operation	T=70°C	96Hrs
4	Low temp operation	T=0°C	96Hrs
5	High temp & high humidity	T=50°C H=90%	96Hrs

Reliability Test Criteria:

Display function should be no change under normal operating condition.



9. Handling Precautions

9.1 Safety

The liquid crystal in the LCD is poisonous. Keep away from your mouth and eyes. If the liquid crystal contacts with your skin, mouse or clothes, use soap to wash it off immediately.

9.2 Handling

- i. The LCD panel is made of very thin glass. Mechanical impact or extrusion to the surface should be prevented.
- ii. The polarizer attached on the display is very easy to be damaged, handle it with special attention.
- iii. To avoid contamination on the display surface, do not touch the display surface with bare hands.
- iv. The transparent electrodes may be disconnected if you use the LCD panel under dew-condensing environment.
- v. The characteristics of the semiconductor devices may be affected when they are exposed to light, possibly resulting in malfunctioning of the ICs. To prevent such malfunctioning of the ICs, make sure the application and the mounting of the panel are designed so that the IC is not exposed to light.

9.3 Static Electricity

Ground soldering iron tips, tools and testers when you operate. Also ground your body when handling the products and store the products in an anti-electrostatic container.

9.4 Storage

Store the products in a dark place where the temperature is within the range of $25\pm 10^{\circ}\text{C}$ and with low humidity (60%RH or less). Do not store the LCD product in an atmosphere containing organic solvents or corrosive gases.

9.5 Cleaning

Do not wipe the polarizer with dry cloth, as it might cause scratching. Wipe the polarizer with a soft cloth soaked with petroleum IPA. Other chemical might damage the panel.



10. QC

10.1 目的

制定 15.6 寸模组产品出货检验标准，明确检验内容和规范；

10.2 范围

适用于 Kingtech Group Co.,Ltd., 使用原装模组、FOG或自购LCD所生产的模组、FOG出货；

10.3 定义

黑白点：显示的点是黑色或者白色，当对比变化时，这些缺陷在大小或强度上没有变化；

亮点：显示中的点（子像素），在显示区域显示为明亮，大小大于 1/2dot，通过 5%的 ND 卡在黑色画面下可见；

碎亮点：在黑画面下看到的发亮的，大小小于 1/2dot 的点；

暗点：显示中的点（子像素），大小大于 1/2dot，在红绿蓝画面的显示区域显示为黑色；

Mura：相对于显示区域的部分背景亮度，部分区域更暗或者更亮的现象（显示画面不均匀）；

二连点：两个相邻的 dot 点；

三连点：三个相邻的 dot 点；

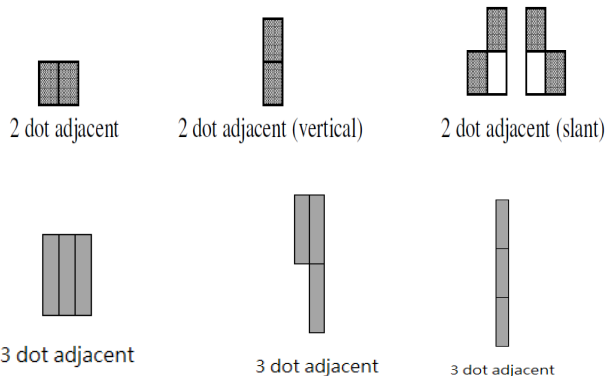
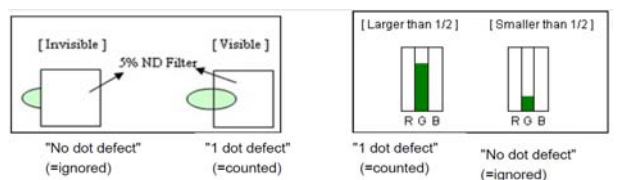

10.4 检验条件

10.4.1 环境要求：温度：25±5℃、湿度：30%–70%RH；

10.4.2 外观检验灯光：20w 荧光灯或等效照度；

10.4.3 检验距离：30cm；



10.4.4 电性检验照度要求：100-200Lux；

10.4.5 外观检验照度要求：500-700Lux；

10.4.6 ND 卡检验要求：ND 放于距 cell 表面 2cm 处，从 30cm 距离检验；

10.4.7 检验角度：做垂直方向 $\pm 45^\circ$ ，水平方向 $\pm 45^\circ$ 夹角检验；

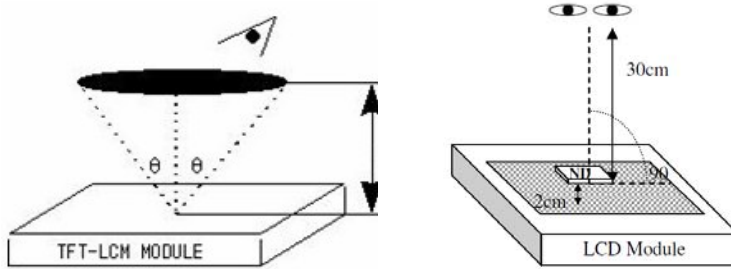

10.4.8 显示区域划分：将显示区长度和宽度方向均匀分为 4 等分，中间 2/4 区域为 I 区，四周为 0 区，见下图：

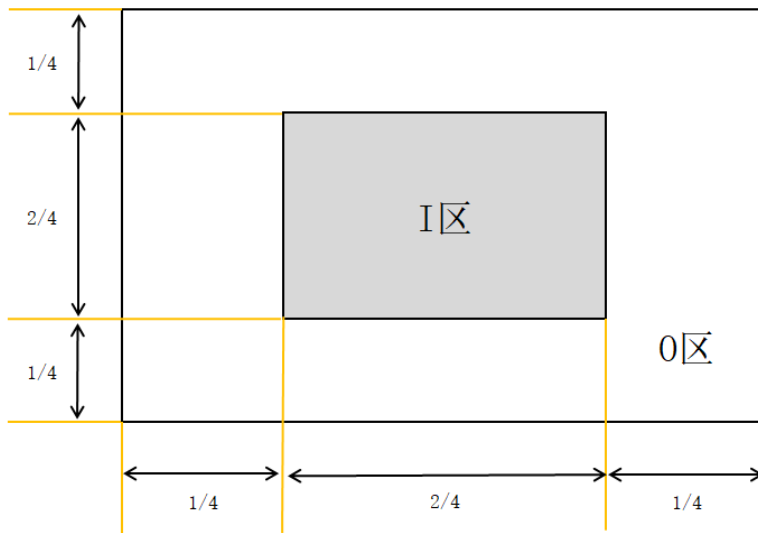



10.5 电性检测

检验项目	检验标准																				
	A0 规			A1 规			A2 规			A3 规			A4 规			B 规					
	I 区	O 区	总数	I 区	O 区	总数	I 区	O 区	总数	I 区	O 区	总数	I 区	O 区	总数	I 区	O 区	总数			
亮点	N≤0			N≤2			N≤4			N≤5			N≤8			N≤10			不计		
二线亮点	N≤0			N≤0			N≤1			DS≥			N≤5			N≤10			不计		
三线亮点	N≤0			N≤0			N≤0			EM			N≤5			N≤10			不计		
暗点	N≤1	N≤5, DS ≥ 10mm	N≤5, DS ≥ 10mm	N≤5, DS ≥10mm		N≤5, DS ≥ 10mm	N≤7		N≤7, DS ≥ 10mm	N≤10			N≤20			N≤10			不计		
二线暗点	N≤0			N≤1			N≤2, DS ≥5mm			EM			N≤7			N≤20			不计		
三线暗点	N≤0			N≤0			N≤1			EM			N≤7			N≤20			不计		
亮点+暗点	N≤5, DS ≥10mm			N≤5, DS ≥10mm			N≤7, DS ≥5mm			/			/			/			/		
脏污点	10xND 逆指不可见, 无视			5xND 逆指不可见, 无视			不计 (测量量不可)			不计 (测量量不可)			不计 (测量量不可)			不计 (测量量不可)			不计		
点状异物 黑点	D≤0.15mm, 数量 N 不计; 0.15mm<D≤0.3mm, N≤3, 间隔≥10mm; 0.3mm<D≤0.4mm, N≤1			D≤0.3mm, 数量 N 不计; 0.3mm<D≤0.8mm, N≤3, 间隔≥10mm;			D≤0.5mm, 数量 N 不计; 0.5mm<D≤0.8mm, N≤3, 间隔≥10mm; 0.8mm<D≤1.2mm, N≤1;			不计			不计			不计			不计		
线状异物	W≤0.1mm, L≤0.3mm, 不计; W≤0.1mm, L≤2mm, N≤2, DS≥10mm;			W≤0.1mm, 不计; 0.1mm<W≤0.2mm, 0.8mm<L≤4mm, N≤3;			W≤0.1mm, 不计; 0.1mm<W≤0.3mm, 0.8mm<L≤8mm, N≤3;			W≤0.1mm, 不计; 0.1mm<W≤0.5mm, 0.8mm<L≤4mm, N≤5;			不计			不计			不计		
POL 气泡	D≤0.2mm, 不计; 0.2mm<D≤0.8mm, N≤2, DS≥10mm 线状按线状异物判定			线状及点状不良参照异物 标准; 边缘气泡不进入 EM 区 1/2 为 OK			线状及点状不良参照异物 标准; 边缘气泡不进入显示区为 OK			不计			5xND 逆指不可见			不计			不计		
Mura	1. 全视角判定, 距离 30mm-50mm 不可见为 OK 2. 轻微 mura 按 10xND 逆指 不可见为 OK			MCS 和灰阶范围不可见, 漏 背景可见, 不计			5xND 逆指不可见			5xND 逆指不可见			不影响电性 OK			不影响电性 OK			不计		
功能缺陷	显示异常、断线(横线、竖线等)、无品、等影响功能的不良不可有																				



10.6 外观检验

检验项目	图示	检验标准					
		A0 级	A1 级	A2 级	A3 级	A4 级	B 级
FAD 区角落破损		$X \leq 1.5mm, Y \leq 1.5mm, Z \leq T, N \leq 2$ 不伤及线路, 显示正常			不伤及线路, 显示正常		
FAD 区边缘破损		$T \leq 0.3, X \leq 2.0, Z \leq T, N \leq 2$ 不伤及线路, 显示正常			不伤及线路, 显示正常		
非 FAD 区角落破损		$X \leq 1.5mm, Y \leq 1.5mm, Z \leq T, N \leq 2$ 不伤及线路, 显示正常			不伤及线路, 显示正常		
非 FAD 区边缘破损		$X \leq 1.5mm, Y \leq 0.3mm, Z \leq T, N$ 不计, 不伤及线路, 显示正常			不伤及线路, 显示正常		
表面点	无图	$D \leq 0.3mm$, 数量 N 不计; $0.3mm < D \leq 0.8mm, N \leq 3$, 间距 $\geq 10mm$;			不计		
表面划伤	无图	$W \leq 0.1mm$, 不计; $0.1mm < W \leq 0.2mm, 0.8mm < L \leq 4mm, N \leq 3$;			不计		
FPC/PCB	无图	<ol style="list-style-type: none"> 定位孔破损不可有 FPC 死折不可有 元件脱落不可有 元件虚焊、溢锡等焊接不良不可有 金手指断、脱不可有 元件卡不到位不可有 FPC 锡球对位偏移不可有 FPC 上双面胶脱落或异常不可有 指窗不能松动, 不影响触摸 			<ol style="list-style-type: none"> 元件脱落, 不可有 元件虚焊、溢锡等焊接不良, 不可有 		
保护膜	无图	<ol style="list-style-type: none"> 划伤不可有, 其他划伤、印记等无视 易擦贴膜面脱落 			有保护膜		
裂纹		不可有					

- W : Width
- L : Length
- D : Average Diameter
- N : Count

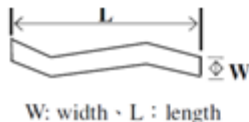

10.7 质保期限

10.7.1 保修 12 个月 (如有合同, 以合同为准)。

end.